

Filtro FTR-ePM10 50% (M5) D.155x40

BRAVO M

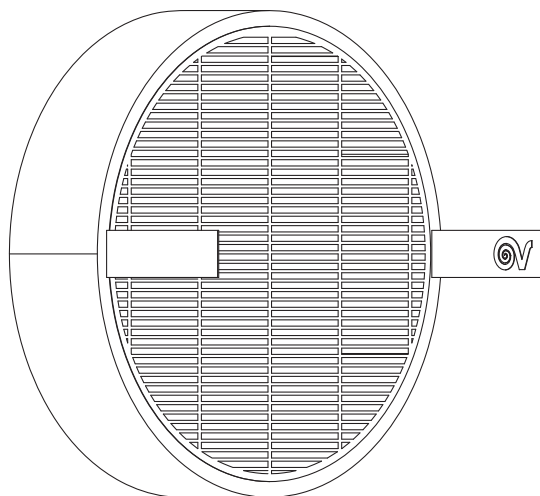

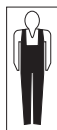

ATTENZIONE:

L'installazione e l'attività di pulizia/sostituzione di questo accessorio presuppongono lo smontaggio di BRA.VO M dalla parete. Per eseguire l'attività rivolgersi a personale professionalmente qualificato.

WARNING

Installation and cleaning/replacement activity of this accessory require the removal of BRA.VO M from the wall. To carry out the activity, contact professionally qualified personnel.

Installazione filtro M5 in sostituzione del prefiltro.
M5 filter installation to replace the prefilter.

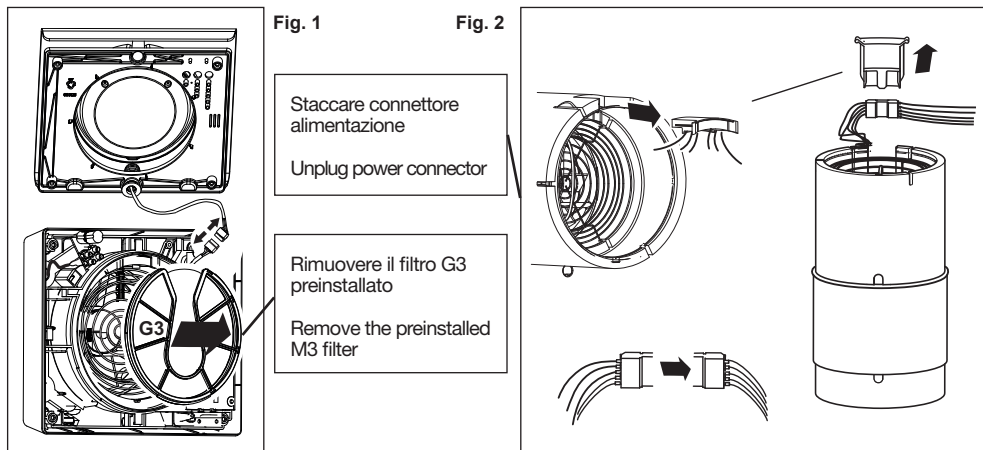

Fig. 3

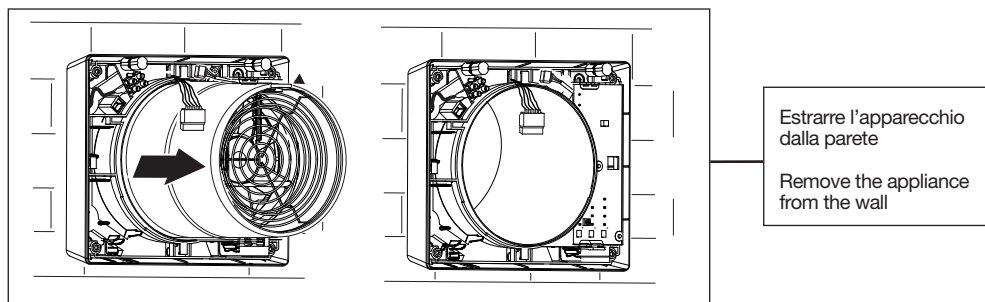

Fig. 4

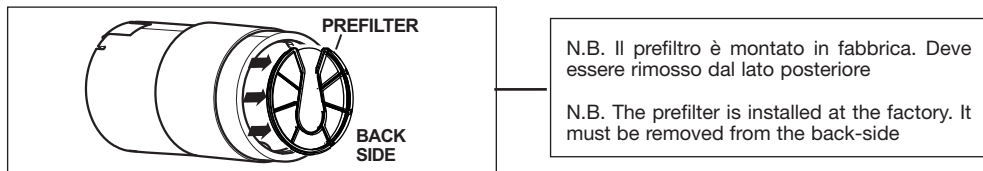
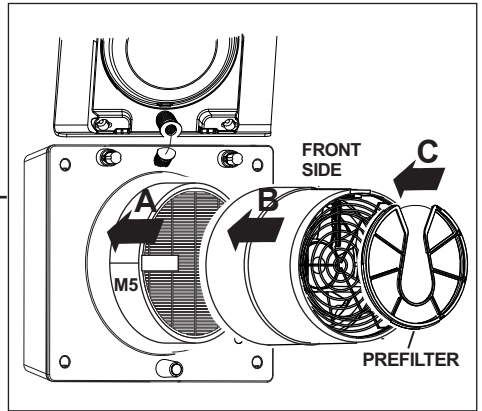

Fig. 5

- A** Inserire il filtro M5 nel tubo all'interno del muro
 - B** Inserire l'apparecchio nel tubo
 - C** Posizionare il prefiltro sul lato anteriore dell'apparecchio
-
- A** Insert M5 filter in the pipe inside the wall
 - B** Insert the appliance in the pipe
 - C** Place the prefilter on the front side of the appliance



Sostituzione filtro M5
Replacement of M5 filter

Fig. 6

Dopo aver smontato l'apparecchio dalla parete, rimuovere dal tubo il filtro e rimpiazzarlo con uno nuovo.

After having removed the appliance from the wall, remove the filter from the pipe and replace it with a new one.

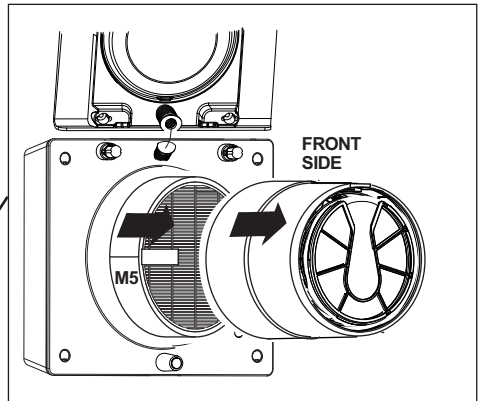
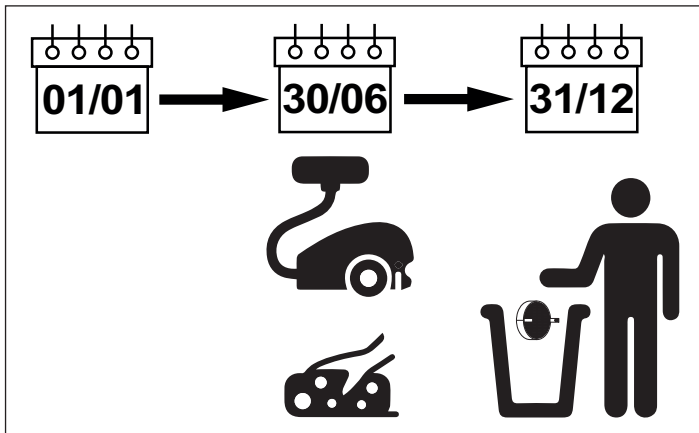

Fig. 7





La società Vortice S.p.A. si riserva il diritto di apportare tutte le varianti migliorative ai prodotti in corso di vendita.
The company Vortice S.p.A. reserves the right to make improvements to products at any time and without prior notice.
La société Vortice S.p.A. se réserve le droit d'apporter toutes les variations afin d'améliorer ses produits en cours de commercialisation.
Die Firma Vortice S.p.A. behält sich vor, alle eventuellen Verbesserungsänderungen an den Produkten des Verkaufsangebots vorzunehmen.
La compañía Vortice S.p.A. se reserva el derecho de incorporar todas las mejoras necesarias a los productos en fase de venta.
Vortice S.p.A. 公司 股份有限公司 保留在产品销售期间进行产品改良的权利。

VORTICE S.p.A.
Strada Cerca, 2 - frazione di Zoate
20067 TRIBIANO (MI)
Tel. +39 02-90.69.91
ITALIA
vortice.com
postvendita@vortice-italy.com

VORTICE LIMITED
Beeches House - Eastern Avenue
Burton on Trent
DE13 0BB
Tel. +44 1283-492949
UNITED KINGDOM
vortice.ltd.uk
sales@vortice.ltd.uk

VORTICE LATAM S.A.
3er Piso, Oficina 9-B, Edificio
Meridiano
Guachipelín, Escazú, San José
PO Box 10-1251
Tel +506 2201 6242;
COSTA RICA
vortice-latam.com
info@vortice-latam.com

VORTICE VENTILATION SYSTEM (CHANGZHOU) CO., LTD
Building 19 , No.388 West Huanghe Road, Xinbei District,
Changzhou, Jiangsu Province CAP:213000
CHINA
vortice-china.com
vortice@vortice-china.com
